

LCGATEWAY/4G

Installation Guide

# Gateway 4G Manual



**RAB** | Controls

# Welcome to lighting control that just works.

Lightcloud is a wireless, cloud-based lighting control system that's incredibly easy to install. There's no networking or complicated dip switches. Just wire the devices for power and let us know what was installed.

# Table of Contents

- 4. Contents
- 5. Device Specifications
- 6. System Overview
- 7. Gateway 4G
- 8. Installation
  - 8. Attach the Antennae
  - 8. Position the Gateway 4G
  - 10. Record the Gateway's Device ID
  - 12. Permanently Install Gateway
  - 14. Install and Document Other Lightcloud Devices
  - 14. Submit Device Information
  - 14. Installation Complete

# Contents

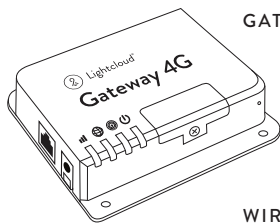

GATEWAY 4G

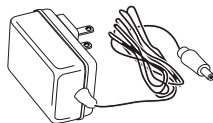

POWER SUPPLY



MESH ANTENNA

WIRE NUTS X2



PANEL STICKER

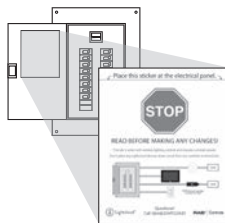

CELLULAR ANTENNAE X2

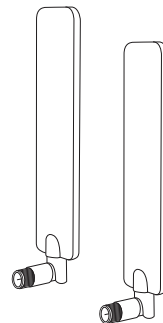

Gateway 4G

Cellular Antennae

Mesh Antenna

Power Supply

Wire Nuts

Mounting Screws

Manual

Device Table

Panel Sticker

Device ID Labels

MOUNTING SCREWS X2



DEVICE ID LABELS

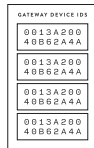

DEVICE TABLE



MANUAL



# Device Specifications

## PART NUMBER

LCGATEWAY/4G

## OPERATING TEMPERATURE

-30C to 70C

## RELATIVE HUMIDITY

5% to 95% (non-condensing)

## STORAGE AND TRANSPORTATION TEMPERATURE

-40C to 85C

## DIMENSIONS

4" Length, 3" Width, 1" Depth

Weight: 0.22lbs (0.5kg)

## DC POWER INPUT

Only use with provided Power Supply

## VOLTAGE INPUT

5 VDC +/- 5%

## POWER CONSUMPTION

3.5W (Typical) 11W (Max)

## CONNECTOR

2.5mm x 5.7mm, center pin positive

Custom manufactured in China

Copyright © 2018 RAB Lighting, Inc.



# System Overview

Lightcloud is a wireless, networked lighting control system that enables near limitless control over lighting. Lightcloud can be accessed from nearly anywhere and any device by logging in to [control.lightcloud.com](http://control.lightcloud.com).

Lightcloud comes with 10 years of unlimited support, so feel free to contact us if you have any questions at **1 (844) LIGHTCLOUD**.

# Gateway 4G

The Lightcloud Gateway serves two main functions.

1. On-Site Coordination of Devices

The Gateway acts as an on-site brain for up to 200 Lightcloud devices.

2. Off-Site Coordination with Lightcloud

The Gateway communicates wirelessly with the Lightcloud cloud for complete control of your system from anywhere.

An unlimited number of Gateways can be used for wireless control of any size site.

# Installation

## 1 STEP ONE

Attach the Antennae and power supply

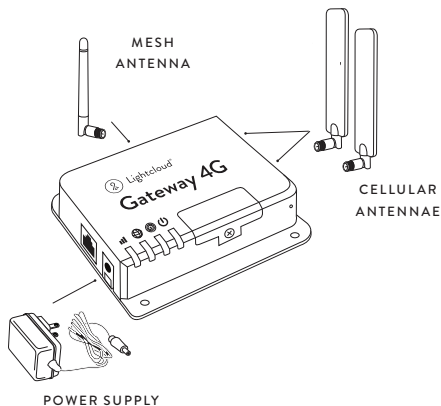

## 2 STEP TWO

Position the Gateway

a. *Avoid Problem Materials and Devices.*

Don't place the Gateway in a metal enclosure, thick concrete or brick rooms. Also don't place the Gateway near microwaves, elevator rooms, amplifiers, or other antennas.

### PROBLEM MATERIALS



METAL



CONCRETE



BRICK

### PROBLEM DEVICES & SIGNALS



MICROWAVES



ELEVATOR MECHANICAL ROOMS



AMPLIFIERS & ANTENNAS



b. Choose a location that is as close to as many other Lightcloud devices as possible.

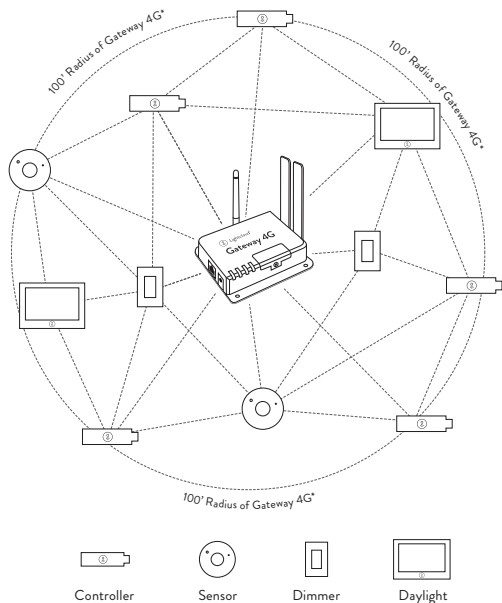

\*All of the devices don't have to be within a 100' of the Gateway 4G, but it's ideal to have as many within direct range as possible.

c. Test the cellular signal.

Plug-in the Gateway and check the cellular signal strength. The cellular signal strength LED should be solid green. Yellow is also adequate but not ideal. If the cellular signal strength LED is off, move the Gateway to a new location and test again.

3 STATE SIGNAL STRENGTH INDICATOR LIGHT  
- DARK (OFF), YELLOW, GREEN

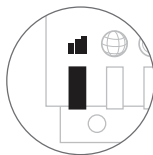

Color	Description
DARK (OFF)	None (or very poor) cellular signal. Relocating device to a better location is recommended.
YELLOW	Adequate cellular signal. This signal strength works for most applications.
GREEN	Optimal cellular signal. This signal level is preferred for device to operate at peak performance.

# Installation

## 3 STEP THREE

### Record the Gateway's Device ID

Each Lightcloud device has a unique Device ID for identification that needs to be documented. To document the Device IDs, use one of the following 3 methods.

- a. *LC Installer App - Free*  
Scan Device ID's and send information to RAB  
Download: [lightcloud.com/lcinstaller](http://lightcloud.com/lcinstaller) (Available for iOS and Android)

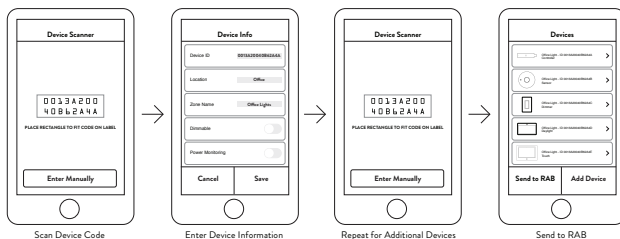

- b. *Device Table - Included with the Gateway*

Attach Device ID stickers to Device Table and complete information.  
Send detailed photos of completed device table to [support@lightcloud.com](mailto:support@lightcloud.com)

*Additional Device Tables can be downloaded at [lightcloud.com/devicetable](http://lightcloud.com/devicetable)*

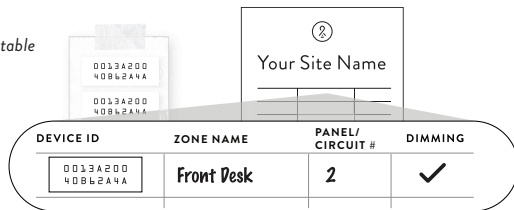

c. Floor Plan

Attach the Device Identification sticker to its location on a floor plan, lighting design, or design schedule. Send detailed photos of completed plans to support@lightcloud.com.

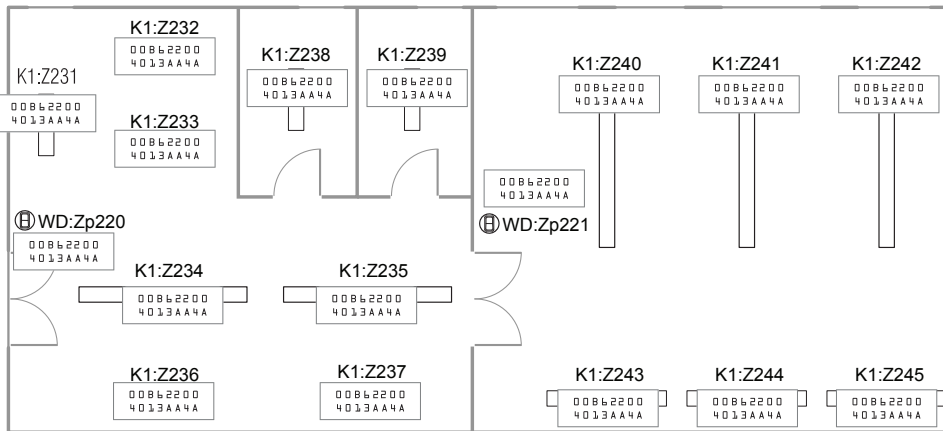

# Installation

## 4 STEP FOUR

### Permanently Install Gateway

- Mount Gateway to wall using 2 supplied screws.
- Plug AC adapter into unswitched outlet.
- Position Antennae

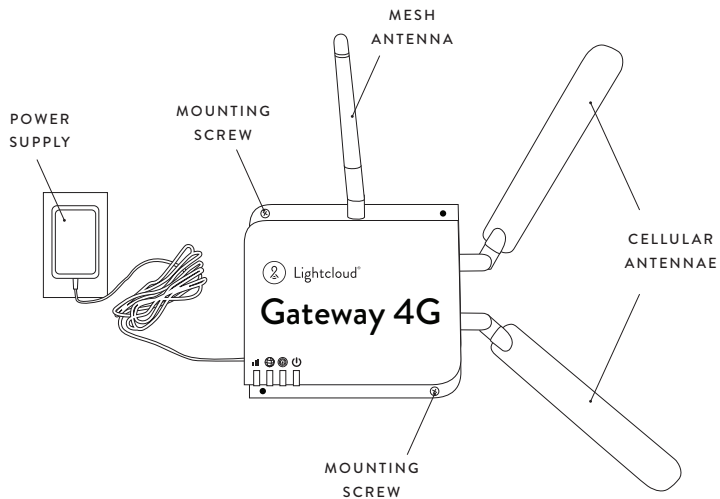

#### d. Verify System Status

The system status LED should be green. It may take a few minutes for the Gateway to connect to Lightcloud.

3 STATE SYSTEM STATUS INDICATOR LIGHT- DARK (OFF), YELLOW, GREEN



Color	Blinking Pattern	Description
OFF	None (Dark)	Gateway 4G is off
YELLOW	Slow blinking yellow	Gateway 4G is running but no network link is established or IP address assigned.
	Solid yellow	An IP address has been assigned to the Gateway 4G.
	Yellow blinking fast (One blink per second)	A network issue has occurred. The two most common remote manager connectivity-related reasons for this state are as follows: 1. Gateway 4G can't connect to a DNS server to resolve the remote manager server address. 2. Gateway 4G can't connect to an NTP time server to get the correct time.
YELLOW/ GREEN	Solid yellow to blinking green	Gateway 4G is attempting a connection to a remote manager server.
GREEN	Green blinking fast (One blink per second)	Remote manager server found and the Gateway 4G is undergoing authentication.
	Solid green	Gateway 4G is connected to the remote manager server.

## 5 STEP FIVE

### Install and Document Other Lightcloud Devices

- a. Follow the Device Manuals to wire the other devices for permanent, unswitched power.
- b. As you wire each device, document their Device IDs using the same method you chose to document the Gateway's Device ID in step 3.

## 6 STEP SIX

### Submit Device Information

After wiring and organizing all of the devices, submit the device information using the LC Installer App or email photos of the documented device IDs to [support@lightcloud.com](mailto:support@lightcloud.com).

## 7 STEP SEVEN

### You're Done!

Lightcloud Support will remotely configure the system.

*FCC Information:*

*This device complies with Part 15 of the FCC Rules. Operation is subject to the following two conditions:*

- 1. This device may not cause harmful interference, and*
- 2. This device must accept any interference received, including interference that may cause undesired operation.*

*Note: This device has been tested and found to comply with the limits for Class B digital devices pursuant to Part 15 Subpart B, of the FCC rules. These limits are designed to provide reasonable protection against harmful interference in a residential environment. This equipment generates, uses, and can radiate radio frequency energy, and if not installed and used in accordance with the instruction manual, may cause harmful interference to radio communications. However, there is no guarantee that interference will not occur in a particular installation. If this equipment does cause harmful interference to radio or television reception, which can be determined by turning the equipment off and on, the user is encouraged to try and correct the interference by one or more of the following measures:*

- Reorient or relocate the receiving antenna.*
- Increase the separation between the equipment and receiver.*
- Connect the equipment into an outlet on a circuit different from that to which the receiver is connected.*
- Consult the dealer or an experienced radio/TV technician for help.*

*To comply with the FCC's RF exposure limits for general population / uncontrolled exposure, this transmitter must be installed to provide a separation distance of at least 20 cm from all persons and must not be co-located or operating in conjunction with any other antenna or transmitter.*

*CAUTION: Changes or modifications to this equipment not expressly approved by RAB Lighting may void the user's authority to operate this equipment.*

